

1752/6458

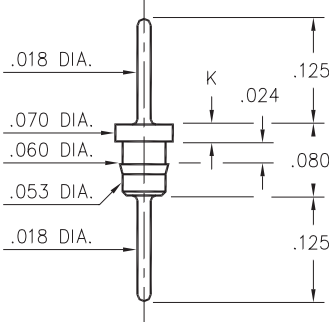

Basic Part Number	Length K
1752-0	.020
6458-0	.035

XXXX-0-00-XX-00-00-03-0
Press-fit in .057 mounting hole

3413/8404

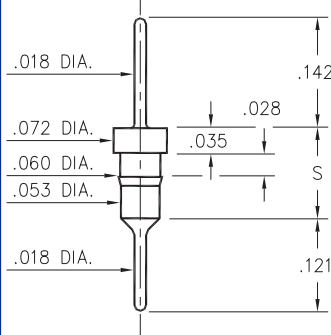

Basic Part Number	Length S
3413-0	.118
8404-0	.131

X4XX-0-00-XX-00-00-03-0
Press-fit in .057 mounting hole

9075

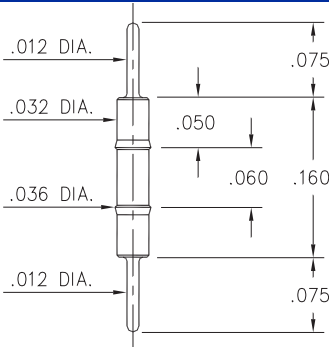

9075-0-00-XX-00-00-03-0
Press-fit in .034 mounting hole

9218

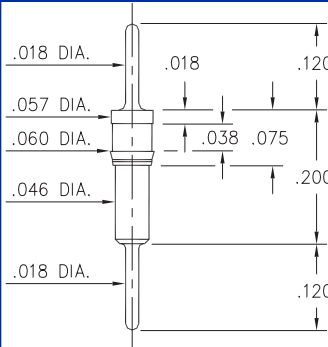

9218-0-00-XX-00-00-03-0
Press-fit in .057 mounting hole

2617

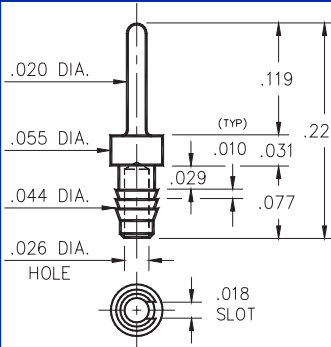

2617-0-01-XX-00-00-03-0
Compliant press-fit in .040 ±.003 hole. For .060 → .100 thick board

8995

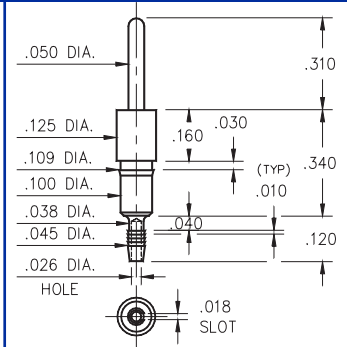

8995-0-01-XX-00-00-03-0
Compliant press-fit in .040 ±.003 hole. For .060 → .100 thick board

SPECIFICATIONS

PIN MATERIAL:
Brass Alloy 360, 1/2 Hard
(Except where noted)

DIMENSION IN INCHES
TOLERANCES ON:
LENGTHS: ±.005
DIAMETERS: ±.002
ANGLES: ± 2°

ORDER CODE: XXXX - X - XX - XX - 00 - 00 - 0X - 0

BASIC PART #

SPECIFY PIN FINISH:
01 200μ" TIN/LEAD OVER NICKEL
80 200μ" TIN OVER NICKEL
15 10μ" GOLD OVER NICKEL
21 20μ" GOLD OVER NICKEL
34 50μ" GOLD OVER NICKEL

